

TECHNICAL MANUAL

OPERATOR'S, ORGANIZATIONAL, DIRECT  
SUPPORT, AND GENERAL SUPPORT  
MAINTENANCE REPAIR PARTS AND SPECIAL  
TOOLS LIST (INCLUDING DE POT MAINTENANCE  
REPAIR PARTS AND SPECIAL TOOLS)  
FOR  
SHELTER, ELECTRICAL EQUIPMENT  
S-280C/G

(NSN 5411-01-092-0892)



**OPERATOR'S, ORGANIZATIONAL, DIRECT SUPPORT,  
 AND GENERAL SUPPORT MAINTENANCE REPAIR PARTS  
 AND SPECIAL TOOLS LIST  
 (INCLUDING DEPOT MAINTENANCE REPAIR  
 PARTS AND SPECIAL TOOLS)**

FOR

**SHELTER, ELECTRICAL EQUIPMENT S-280 C/G  
 (NSN 5411-01-092-0892)**

Current as of 9 September 1981

**REPORTING ERRORS AND RECOMMENDING IMPROVEMENTS**  
 You can help improve this manual. If you find any mistakes or if you know of a way to improve the procedures, please let us know. Mail your letter, DA Form 2028 (Recommended Changes to Publications and Blank Forms), or DA Form 2028-2 located in back of this manual direct to: Commander, US Army Communications-Electronics Command, ATTN: DRSEL-ME-MQ, Fort Monmouth, NJ 07703.  
 In either case, a reply will be furnished direct to you.

Table of Contents

		Page	Illus Figure
Section	I. Introduction . . . . .	1	
	II. Repair Parts List . . . . .	5	
Group	00 Shelter, Electrical Equipment S-280C/G. . . . .	5	1
	01 Door Assembly . . . . .	9	2
	02 Skid Assembly . . . . .	11	3
	03 Lifting and Tie Eye Assembly (No parts authorized		
	04 Towing Eye Assembly (No parts authorized)		
	05 DoorBraceAssembly . . . . .	13	4
	06 Pan Assembly, Recessed Step (See Group 00 for listing of parts)		
Section	III. Special Tools List (Nonapplicable)		
	IV. National Stock Number and Part Number Index . . . . .	14	
Appendix	A. COMPONENT OF END ITEM LIST (Not applicable)		
	B. ADDITIONAL AUTHORIZATION LIST (Not applicable)		
	C. MAINTENANCE ALLOCATION		
Section	I. Introduction . . . . .		C-1
	II. Maintenance Allocation Chart. . . . .		C-3
	III. Tools and Text Equipment Requirements . . . . .		C-4
	IV. Remarks . . . . .		C-5
Appendix	D. EXPENDABLE SUPPLIES AND MATERIALS LIST (Not applicable)		



# SECTION I

## INTRODUCTION

---

### 1. Scope

This manual lists spares and repair parts; special tools; special test, measurement, and diagnostic equipment (TMDE), and other special support equipment required for performance of operator's, organizational, direct support, and general support maintenance of the S-280C/G. It authorizes the requisitioning and issue of spares and repair parts as indicated by the source and maintenance codes.

### 2. General

This Repair Parts and Special Tools List is divided into the following sections:

*a. Section II. Repair Parts List.* A list of spares and repair parts authorized for use in the performance of maintenance. The list also includes parts which must be removed for replacement of the authorized parts. Parts lists are composed of functional groups in numeric sequence, with the parts in each group listed in figure and item number sequence.

*b. Section III. Special Tools List.* Not applicable.

*c. Section IV. National Stock Number and Part Number Index.* A list, in National item identification number (NIIN) sequence, of all National stock numbers (NSN) appearing in the listings, followed by a list, in alphameric sequence, of all part numbers appearing in the listings. National stock numbers and part numbers are cross-referenced to each illustration figure and item number appearance.

### 3. Explanation of Columns

*a. Illustration.* This column is divided as follows:

(1) *Figure number.* Indicates the figure number of the illustration on which the item is shown.

(2) *Item number.* The number used to identify item called out in the illustration.

*b. Source, Maintenance, and Recoverability (SMR) Codes.*

(1) *Source code.* Source codes indicate the manner of acquiring support items for maintenance, repair, or overhaul of end items. Source codes are entered in the first and second positions of the Uniform SMR Code format as follows:

<i>Code</i>	<i>Definition</i>
PA—Item procured and stocked for anticipated or known usage.	

XD—A support item that is not stocked. When required, item will be procured through normal supply channels.

#### NOTE

Cannibalization or salvage may be used as a source of supply for any items source coded above except those coded XA and aircraft support items as restricted by AR 700-42.

(2) *Maintenance code.* Maintenance codes are assigned to indicate the levels of maintenance authorized to USE and REPAIR support items. The maintenance codes are entered in the third and fourth positions of the Uniform SMR Code format as follows:

(a) The maintenance code entered in the third position will indicate the lowest maintenance level authorized to remove, replace, and use the support item. The maintenance code entered in the third position will indicate one of the following levels of maintenance:

<i>Code</i>	<i>Application/Explanation</i>
O—Support item is removed, replaced, used at the organizational level.	
F—Support item is removed, replaced, used at the direct support level.	
H—Support item is removed, replaced, used at the general support level.	

(b) The maintenance code entered in the fourth position indicates whether the item is to be repaired and identifies the lowest maintenance level with the capability to perform complete repair (i.e., all authorized maintenance functions). This position will contain one of the following maintenance codes:

<i>Code</i>	<i>Application/Explanation</i>
F—The lowest maintenance level capable of complete repair of the support item is the direct support level.	
H—The lowest maintenance level capable of complete repair of the support item is the general support level.	
Z—Nonreparable. No repair is authorized.	

(3) *Recoverability code.* Recoverability codes are assigned to support items to indicate the disposition action on unserviceable items. The recoverability code is entered in the fifth position of the Uniform SMR Code format as follows:

Recoverability  
codes

Definition

**Z-Nonreparable item.** When unserviceable, condemn and dispose at the level indicated in position 3.

**F-Reparable item.** When uneconomically reparable, condemn and dispose at the direct support level.

**H-Reparable item.** When uneconomically reparable, condemn and dispose at the general support level.

*c. National Stock Number.* Indicates the National stock number assigned to the item and will be used for requisitioning purposes.

*d. Federal Supply Code for Manufacturer (FSCM).* The FSCM is a 5-digit numeric code listed in SB 708-41/42 which is used to identify the manufacturer, distributor, or Government agency, etc.

*e. Part Number.* Indicates the primary number used by the manufacturer (individual, company, firm, corporation, or Government activity), which controls the design and characteristics of the item by means of its engineering drawings, specifications, standards, and inspection requirements to identify an item or range of items.

#### NOTE

When a stock numbered item is requisitioned, the repair part received may have a different part number than the part being replaced.

*f. Description.* Indicates the Federal item name and, if required, a minimum description to identify the item.

*g. Unit of Measure (UAW).* Indicates the standard of the basic quantity of the listed item as used in performing the actual maintenance function. This measure is expressed by a two-character alphabetical abbreviation (e.g., ea, in, pr, etc). When the unit of measure differs from the unit of issue, the lowest unit of issue that will satisfy the required units of measure will be requisitioned.

*h. Quantity Incorporated in Unit.* Indicates the quantity of the item used in the breakout shown on the illustration figure, which is prepared for a functional group, subfunctional group, or an assembly. A "V" appearing in this column in lieu of a quantity indicates that no specific quantity is applicable, (e.g., shims, spacers, etc).

## 4. Special Information

*a.* The following publication pertains to the S280C/G and its components:  
TM 11-5410-213-14P, Shelters, Electrical Equipment S-280A/G and S-280B/G.

*b.* National stock numbers (NSN's) that are missing from P source coded items have been applied for and will be added to this TM by future change/revision when they are entered in the Army Master Data File (AMDF). Until the NSN's are established and published, submit exception requisitions to: Commander, US Army Communications-Electronics Command, ATTN: DR-SEL-MM, Fort Monmouth, NJ 07703 for the part required to support your equipment.

## 5. How to Locate Repair Parts

*a.* When National stock number or part number is unknown.

(1) *First.* Using the table of contents, determine the functional group within which the item belongs. This is necessary since illustrations are prepared for functional groups and listings are divided into the same groups.

(2) *Second.* Find the illustration covering the functional group to which the item belongs.

(3) *Third.* Identify the item on the illustration and note the illustration figure and item number of the item.

(4) *Fourth.* Using the Repair Parts Listing, find the figure and item number noted on the illustration.

*b.* When National stock number or part number is known.

(1) *First.* Using the Index of National Stock Numbers and Part Numbers, find the pertinent National stock number or part number. This index is in NIIN sequence followed by a list of part numbers in alphameric sequence, cross-referenced to the illustration figure number and item number.

(2) *Second.* After finding the figure and item number, locate the figure and item number in the repair parts list.

## 6. Abbreviations

Not applicable.

(Next printed page is 4.1)

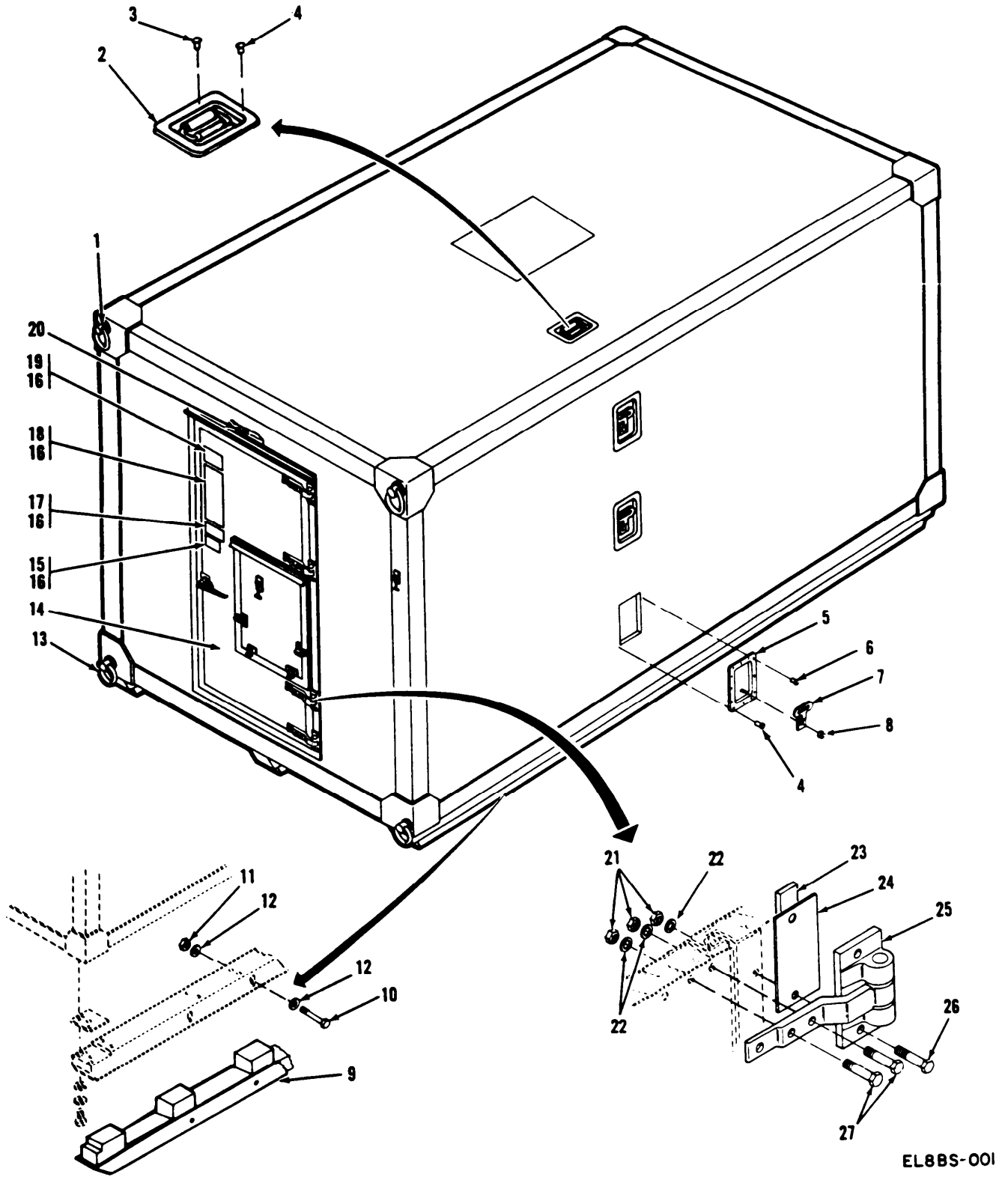

EL8BS-001

Figure 1. Shelter, Electrical Equipment S-280C/G (Sheet 1 of 2)

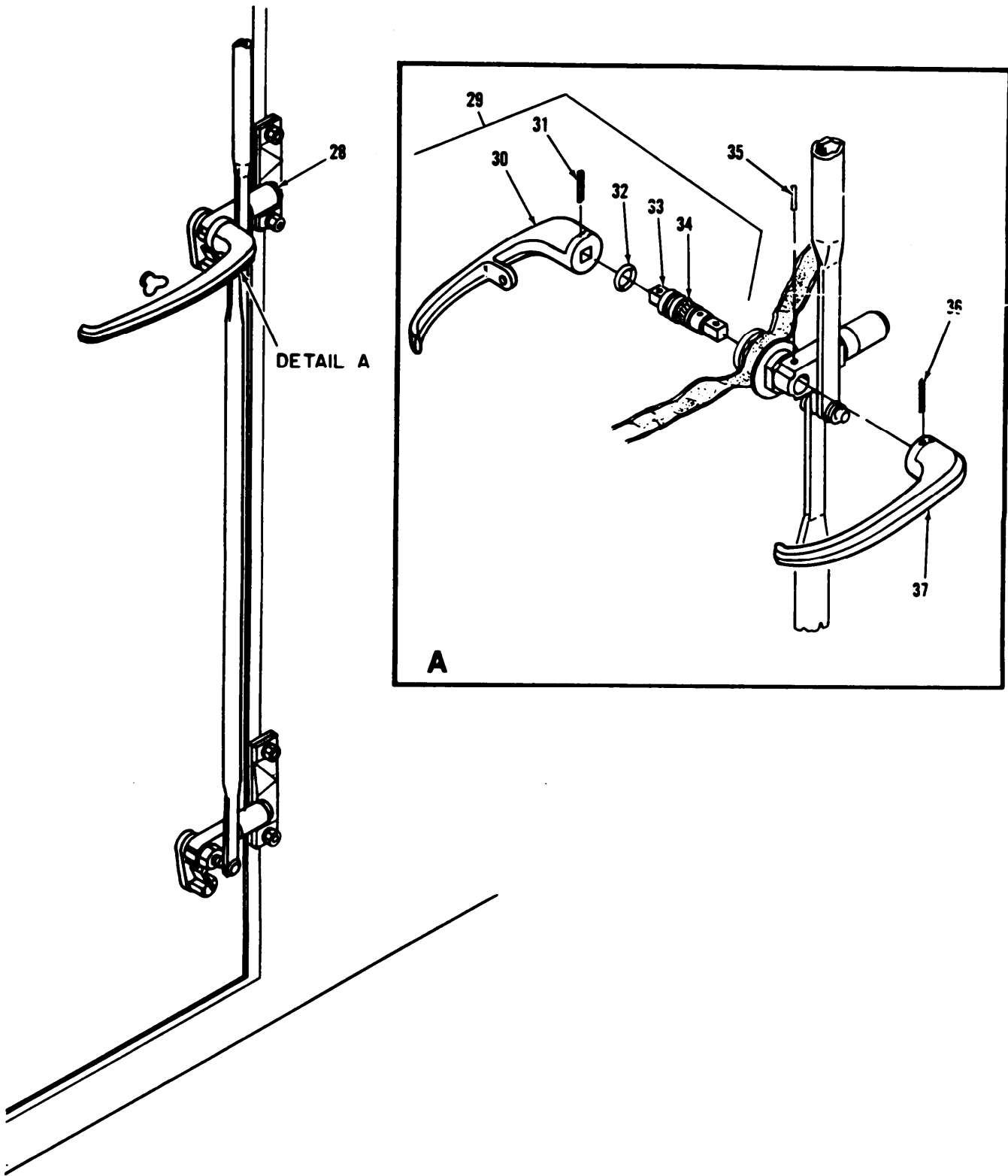

EL88S-002

Figure 1. Shelter, Electrical Equipment S-280C/G (Sheet 2 of 2).



SECTION II (1) ILLUSTRATION		(2)	(3)	TM11-5410-213-14P-1		(6)	(7)	(8)
(A) FIG NO	(B) ITEM NO	SMR CODE	NATIONAL STOCK NUMBER	(4) FSCM	(5) PART NUMBER	DESCRIPTION	USABLE ON CODE U/M	QTY INC IN UNIT
						GROUP 00 SHELTER, ELECTRICAL EQUIPMENT		
						S-280C/G		
1	1	XDFZZ		80063	SM-C-947176	LIFTING EYE ASSY	EA	4
1	2	PAHZZ	5410-00-933-0845	80063	SM-C-165382	HANDHOLD ASSEMBLY	EA	1
1	3	XDHFF		80063	SM-D-947080-1	RIVET,BLIND	EA	197
1	4	XDHFF		80063	SM-D-947080-4	RIVET,BLIND	EA	485
1	5	XDHHH		80063	SM-D-555567	PAN ASSY,STEP	EA	3
1	6	XDFZZ		80063	SM-D-947080-2	RIVET,BLIND	EA	119
1	7	PAFZZ	5410-00-919-4958	19220	1-575709-50	STEP,FOLDING	EA	1
1	8	PAFZZ	5310-00-139-7357	19220	15949	NUT,PLAIN,HEXAGON	EA	1
1	9	XDHHH		80063	SM-D-947171	SKID ASSY	EA	3
1	10	XDFZZ	5306-00-543-5578	96906	MS16208-68	BOLT,MACHINE	EA	18
1	11	XDFZZ		80063	SM-D-947080-18	NUT,HEX	EA	18
1	12	XDFZZ	5310-00-595-6057	96906	MS15795-815	WASHER,FLAT	EA	36
1	13	XDFZZ		80063	SM-C-747147	TOWING EYE ASSY	EA	4
1	14	XDFHH		80063	SM-D-947166	DOOR ASSY	EA	1
1	15	XDFZZ		80063	SM-B-340031	PLATE,AIRBORNE INST	EA	1
1	16	XDFZZ		80063	SM-D-947080-8	RIVET,BLIND	EA	394
1	17	XDFZZ		80063	SM-B-947229	NAMEPLATE	EA	1
1	18	XDFZZ		80063	SM-C-165466	PLATE,TRANSP	EA	1
1	19	XDFZZ		80063	SM-B-947228	PLATE,DATA ACFT	EA	1
1	20	XDFZZ		80063	SC-D-595548	DOOR BRACE ASSY	EA	1
1	21	PAHZZ	5310-00-807-1469	96906	MS21042-5	NUT,SELF-LOCKING,EX	EA	20
1	22	PAHZZ	5310-00-802-4701	96906	MS15795-813	WASHER,FLAT	EA	32
1	23	XDHZZ		80063	SM-B-947146-1	SHIM	EA	V
1	24	XDHZZ		80063	SM-B-162197	SHIP	EA	V
1	25	PAHZZ	5340-00-917-6104	80063	SM-C-317057	HINGE,SPECIAL	EA	4
1	26	PAHZZ	5306-00-182-1513	88044	AN5C-25A	BOLT,MACHINE	EA	12
1	27	PAHZZ		88044	AN5C-26A	BOLT,MACHINE	EA	8
1	28	PAHHH	5340-00-794-4440	80063	SC-D-200140	DOOR LATCH INST	EA	1
1	29	XDHZZ	5340-00-794-4612	80063	SM-C-113597	HANDLE,DOOR	EA	1
1	10	XDHZZ		80063	SM-B-113596-2	HANDLE,MOD	EA	1
1	31	XDHZZ	5315-00-063-9016	96906	MS171657	PIN,SPRING	EA	1
1	32	XDHZZ	5330-00-248-3847	96906	MS29513-115	PACKING,PREFORMED	EA	1
1	33	XDHZZ		80063	SC-B-200155-1	LATCH HANDLE SHAFT	EA	1
1	34	XDHZZ	5330-00-248-3847	96906	MS29513-115	PACKING,PREFORMED	EA	1
1	35	XDHZZ	5315-00-062-5417	96906	MS35674-41	PIN,GROOVED,HEADLES	EA	1
1	36	XDHZZ	5315-00-846-8337	96906	MS171659	PIN,SPRING	EA	1
1	37	XDHZZ	5340-00-794-4610	80063	SM-B-113596-1	HANDLE,DOOR	EA	1



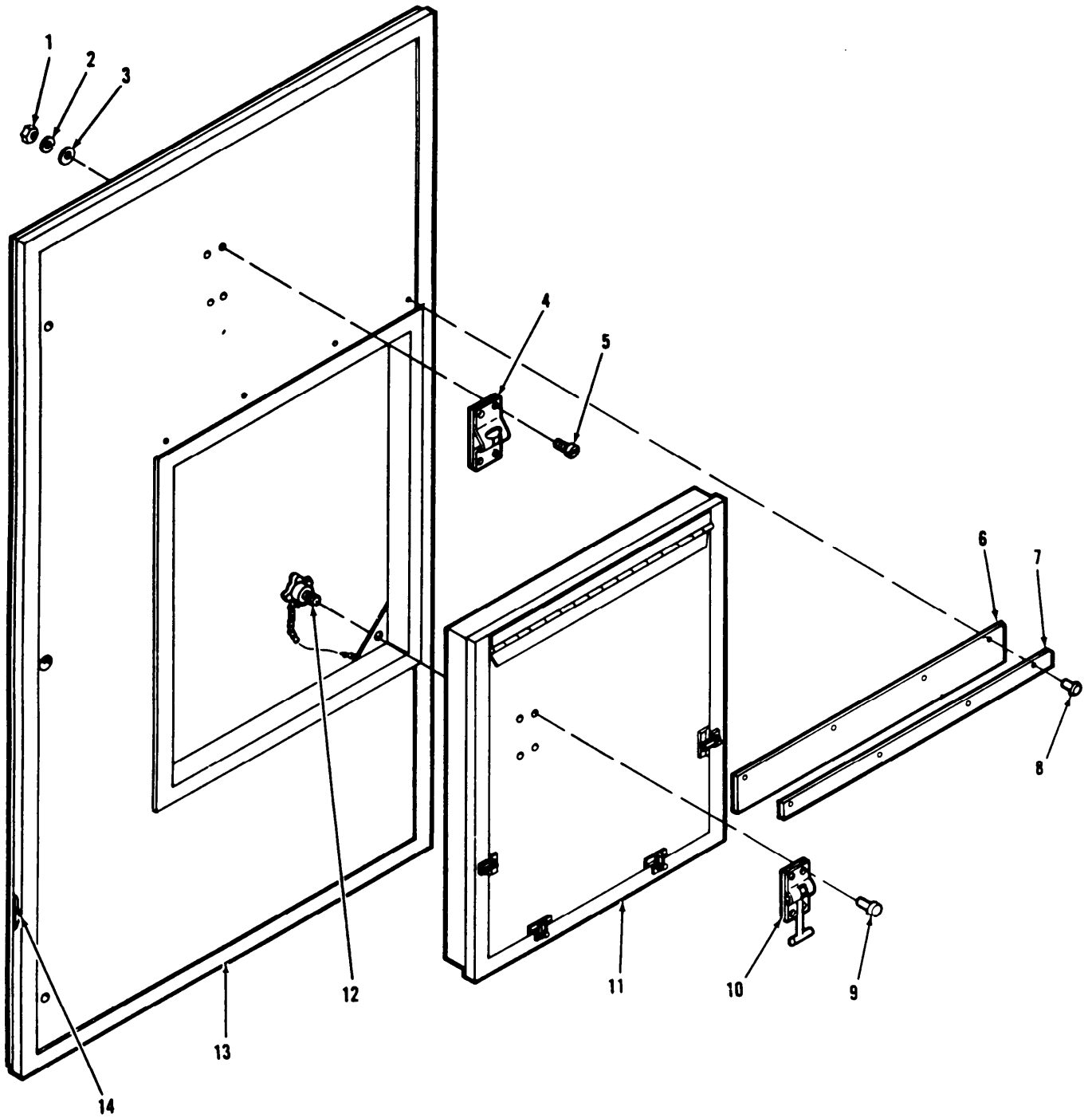

EL88S-003

Figure 2. Door Assembly (Sheet 1 of 2).

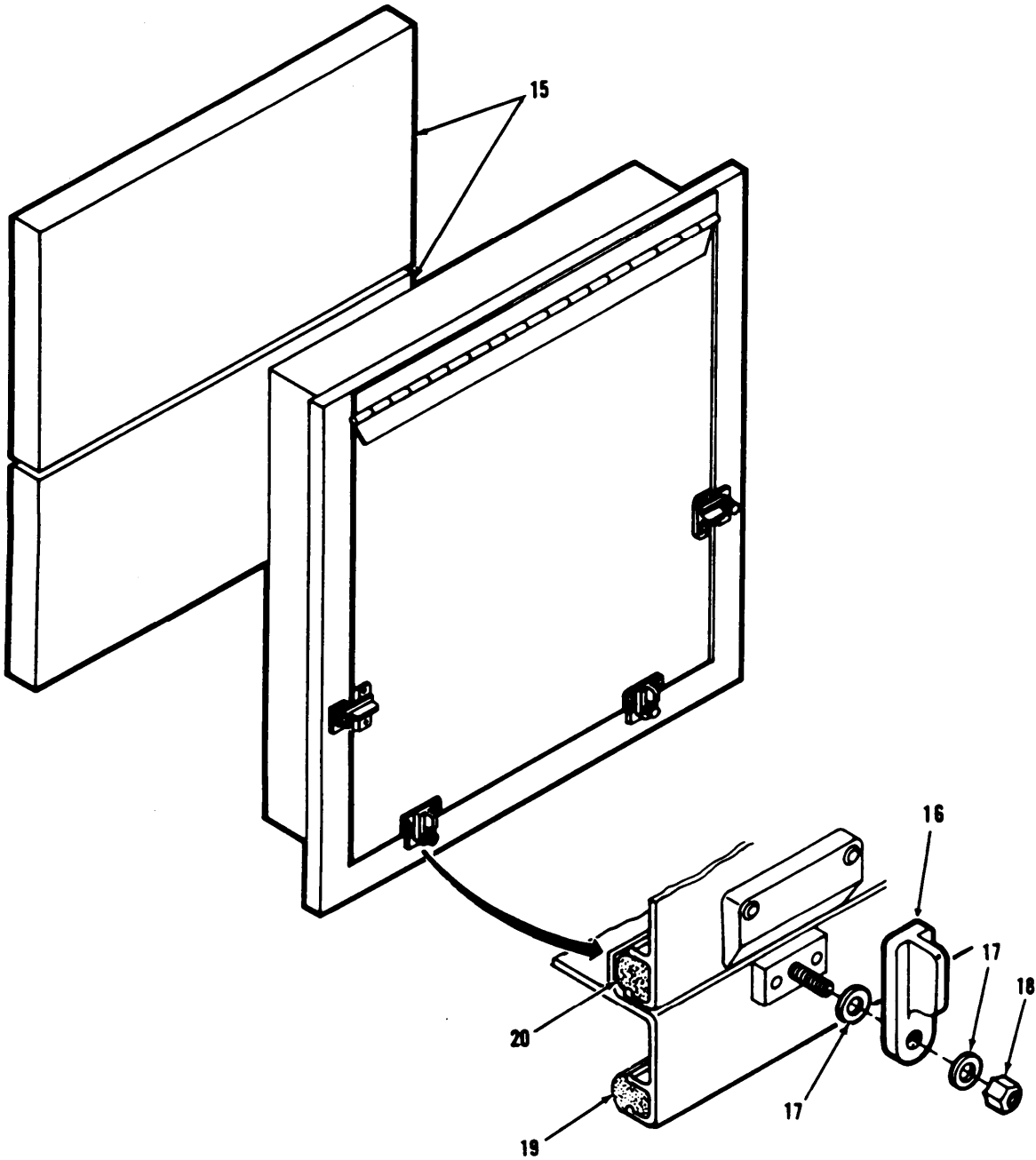

EL88S-004

Figure 2. Door Assembly (Sheet 2 of 2).

SECTION II (1) ILLUSTRATION		TM11-5410-213-14P-1					(6)	(7)	(8)
(A) FIG NO	(B) ITEM NO	(2) SMR CODE	(3) NATIONAL STOCK NUMBER	(4) FSCM	(5) PART NUMBER	DESCRIPTION	USABLE ON CODE	U/M	QTY INC IN UNIT
GROUP 01 DOOR ASSEMBLY									
2	1	PAHZZ	5310-00-934-9758	96906	MS35649-202	NUT, FLAIN, HEXAGON		EA	4
2	2	PAHZZ	5310-00-045-3296	96906	MS35338-43	WASHER, LOCK		EA	4
2	3	PAHZZ	5310-00-809-8546	96906	MS27183-8	WASHER, FLAT		EA	4
2	4	PAHZZ	5340-00-493-9235	80063	SM-B-555598-2	STRIKE, CATCH		EA	1
2	5	PAHZZ	5305-00-984-7364	96906	MS35206-273	SCREW, MACHINE		EA	4
2	6	PAHZZ	9320-00-134-9663	80063	SM-B-555572-6	STRIP, RUBBER		EA	1
2	7	XDHZZ		80063	SM-B-450465	STRIP, DRIP CAP		EA	1
2	8	PAHZZ		80205	NAS1398D6-3	RIVET, BLIND		EA	17
2	9	PAHZZ		80205	NAS139806-5	RIVET, BLIND		EA	4
2	10	XDHZZ	5340-00-928-8999	80063	SM-B-555598-1	LATCH, RIM		EA	1
2	11	XDHZZ		80063	SM-D-450462	PANEL ASSY, EMER		EA	1
2	12	XDHZZ		80063	SM-C-450441	KNOB ASSY		EA	4
2	13	XDHZZ		80063	SM-D-947167	PANEL ASSY DOOR		EA	1
2	14	XDHZZ		80063	SM-D-947166-1	GASKET, SILICONE		EA	1
2	15	PAOZZ	9330-00-107-1165	80063	SM-C-450466	AIR FILTER		EA	2
2	16	XDHZZ	5340-00-118-0018	80063	SM-B-450447	LATCH, SPECIAL		EA	4
2	17	PAHZZ		80063	SM-D-450462-3	WASHER, FLAT NYLON		EA	4
2	18	XDHZZ		80063	SM-D-450462-4	NUT 1/4X20		EA	4
2	19	XDHZZ		80063	SM-D-450462-8	GASKET, SILICONE		EA	1
2	20	XDHZZ		80063	SM-D-450462-7	GASKET, SILICONE		EA	1

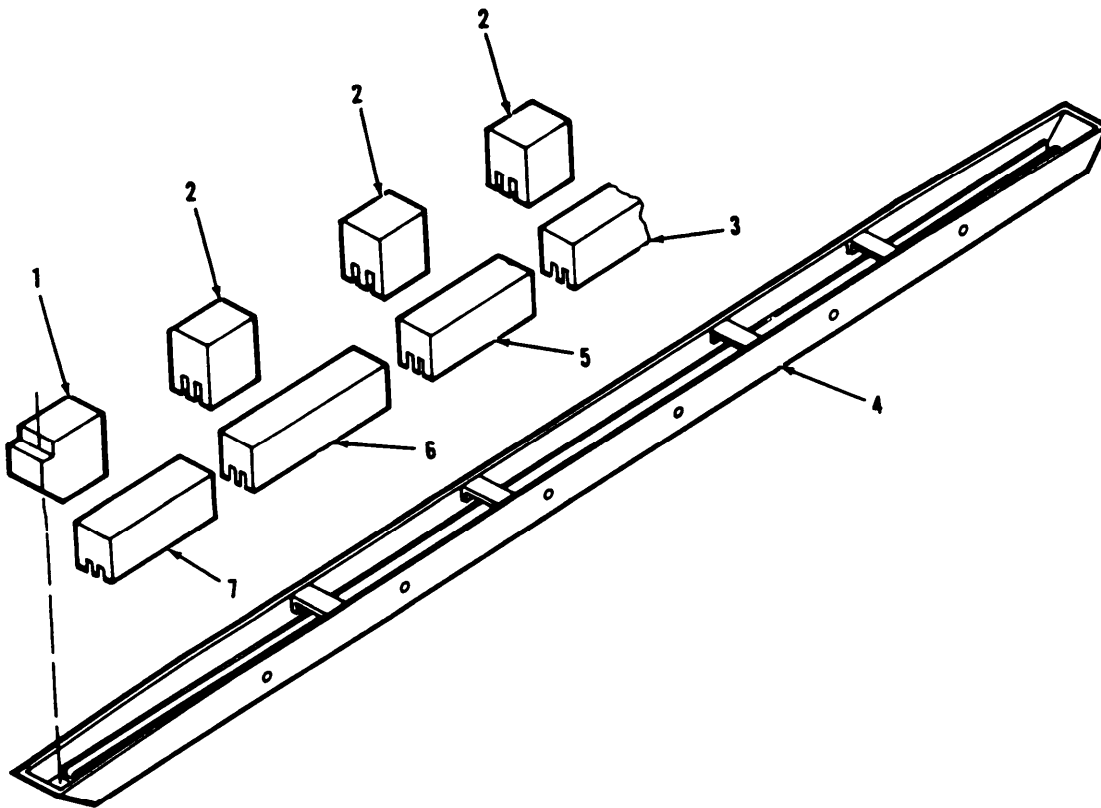

EL8BS-005

Figure 3. Ski d Assembly.

SECTION II		TM11-5410-213-14P-1					
(1)	(2)	(3)	(4)	(5)	(6)	(7)	(8)
ILLUSTRATION		NATIONAL			DESCRIPTION		QTY
(A)	(B)	STOCK	FSCM	PART		USABLE ON CODE	INC
FIG	ITEM	NUMBER		NUMBER			IN
NO	NO						UNIT
GROUP 02 SKID ASSEMBLY							
3	1	XDHZZ	80063	SM-C-947175	SHOCK MOUNT	EA	2
3	2	PAHZZ	80063	SM-C-555515-2	MOUNT, RESILIENT	EA	6
3	3	XDHZZ	80063	SM-B-162191-1	CORE	EA	1
3	4	XDHZZ	80063	SM-D-947172	SKID RUNNER	EA	1
3	5	XDHZZ	80063	SM-C-947174-2	CORE	EA	2
3	6	XDHZZ	80063	SM-C-947174-3	CORE	EA	2
3	7	XDHZZ	80063	SM-C-947174-1	CORE	EA	2

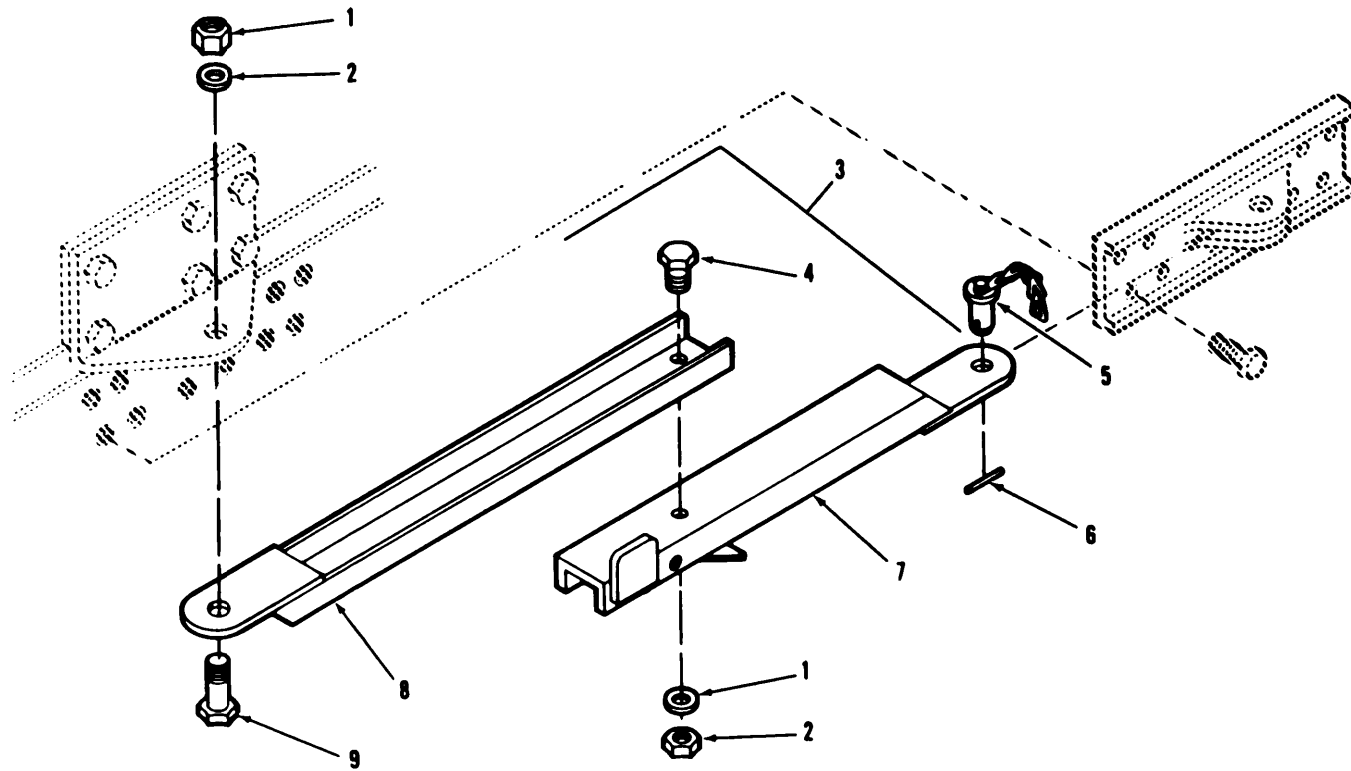

EL8BS-006

Figure 4. Door Brace Assembly.



SECTION II		TM11-5410-213-14P-1						
(1)	(2)	(3)	(4)	(5)	(6)	(7)	(8)	
ILLUSTRATION		NATIONAL			DESCRIPTION		QTY	
(A)	(B)	STOCK	FSCM	PART		USABLE ON CODE	INC	
FIG	ITEM	NUMBER		NUMBER			IN	
NO	NO						UNIT	
GROUP 05 DOOR BRACE ASSEMBLY								
4	1	XDHZZ		80063	SC-D-595078-1		EA 2	
4	2	XDHZZ	5310-00-080-6004	96906	MS27183-14		EA 2	
4	3	PAFZZ	5410-00-007-5164	80063	SC-D-595078		EA 1	
4	4	PAFZZ	5306-00-139-7382	80063	SM-B-564727-1		EA 1	
4	5	PAFZZ	4010-00-436-3300	80063	SM-B-340027		EA 1	
4	6	PAFZZ		96906	MS24665-285		EA 1	
4	7	XDHZZ		80063	SC-C-200157		EA 1	
4	8	XDHZZ		80063	SC-C-200158		EA 1	
4	9	PAFZZ	5306-00-139-7381	80063	SM-B-564727-2		EA 1	

## SECTION IV

## NATIONAL STOCK NUMBER AND PART NUMBER INDEX

TM11-5410-213-14P-1

STOCK NUMBER	FIGURE NO	ITEM NO	STOCK NUMBER	FIGURE NO	ITEM NO
5410-00-007-5164	4	3	5306-00-543-5578	1	10
5310-00-045-3296	2	2	5310-00-595-6057	1	12
5315-00-062-5417	1	35	5340-00-794-4440	1	28
5315-00-063-9016	1	31	5340-00-794-4610	1	37
5310-00-080-6004	4	2	5340-00-794-4612	1	29
9330-00-107-1165	2	15	5310-00-802-4701	1	22
5340-00-118-0018	2	16	5310-00-807-1469	1	21
9320-00-134-9663	2	6	5310-00-809-8546	2	3
5310-00-139-7357	1	8	5315-00-846-8337	1	36
5306-00-139-7381	4	9	5340-00-917-6104	1	25
5306-00-139-7382	4	4	5410-00-919-4958	1	7
5306-00-182-1513	1	26	5340-00-928-8999	2	10
5330-00-248-3847	1	32	5410-00-933-0845	1	2
5330-00-248-3847	1	34	5310-00-934-9758	2	1
4010-00-436-3300	4	5	5305-00-984-7364	2	5
5340-00-493-9235	2	4			

FSCM	PART NUMBER	FIGURE NO	ITEM NO	FSCM	PART NUMBER	FIGURE NO	ITEM NO
88044	AN5C-25A	1	26	80063	SM-B-564727-1	4	
88044	AN5C-26A	1	27	80063	SM-B-564727-2	4	9
96906	MS15795-813	1	22	80063	SM-B-947146-1	1	23
96906	MS15795-815	1	12	80063	SM-B-947228	1	19
96906	MS16208-68	1	10	80063	SM-B-947229	1	17
96906	MS171657	1	31	80063	SM-C-113597	1	29
96906	MS171659	1	36	80063	SM-C-165382	1	2
96906	MS21042-5	1	21	80063	SM-C-165466	1	18
96906	MS24665-285	4	6	80063	SM-C-317057	1	25
96906	MS27183-14	4	2	80063	SM-C-450441	2	12
96906	MS27183-8	2	3	80063	SM-C-450466	2	15
96906	MS29513-115	1	32	80063	SM-C-555515-2	3	2
96906	MS29513-115	1	34	80063	SM-C-747147	1	13
96906	MS35206-273	2	5	80063	SM-C-947174-1	3	7
96906	MS35338-43	2	2	80063	SM-C-947174-2	3	5
96906	MS35649-202	2	1	80063	SM-C-947174-3	3	6
96906	MS35674-41	1	35	80063	SM-C-947175	3	1
80205	NAS1398D6-3	2	8	80063	SM-C-947176	1	1
80205	NAS1398D6-5	2	9	80063	SM-D-450462	2	11
80063	SC-B-200155-1	1	33	80063	SM-D-450462-3	2	17
80063	SC-C-200157	4	7	80063	SM-D-450462-4	2	18
80063	SC-C-200158	4	8	80063	SM-D-450462-7	2	20
80063	SC-D-200140	1	28	80063	SM-D-450462-8	2	19
80063	SC-D-595078	4	3	80063	SM-D-555567	1	5
80063	SC-D-595078-1	4	1	80063	SM-D-947080-1	1	3
80063	SC-D-595548	1	20	80063	SM-D-947080-18	1	11
80063	SM-B-113596-1	1	37	80063	SM-D-947080-2	1	6
80063	SM-B-113596-2	1	30	80063	SM-D-947080-4	1	4
80063	SM-B-162191-1	3	3	80063	SM-D-947080-8	1	16
80063	SM-B-162197	1	24	80063	SM-D-947166	1	14
80063	SM-B-340027	4	5	80063	SM-D-947166-1	2	14
80063	SM-B-340031	1	15	80063	SM-D-947167	2	13
80063	SM-B-450447	2	16	80063	SM-D-947171	1	9
80063	SM-B-450465	2	7	80063	SM-D-947172	3	4
80063	SM-B-555572-6	2	6	19220	1-575709-50	1	7
80063	SM-B-555598-1	2	10	19220	15949	1	8
80063	SM-B-555598-2	2	4				

# APPENDIX C

## MAINTENANCE ALLOCATION

---

### Section I. INTRODUCTION

#### C-1. General.

This appendix provides a summary of the maintenance operations for the S-280C/G. It authorizes categories of maintenance for specific maintenance functions on repairable items and components and the tools and equipment required to perform each function. This appendix may be used as an aid in planning maintenance operations.

#### C-2. Maintenance Function.

Maintenance functions will be limited to and defined as follows:

*a. Inspect.* To determine the serviceability of an item by comparing its physical, mechanical, and/or electrical characteristics with established standards through examines.

*b. Test.* To verify serviceability and to detect incipient failure by measuring the mechanical or electrical characteristics of an item and comparing those characteristics with prescribed standards.

*c. Service.* Operations required periodically to keep an item in proper operating condition, i.e., to clean (decontaminate), to preserve, to drain, to paint, or to replenish fuel, lubricants, hydraulic fluids, or compressed air supplies.

*d. Adjust.* To maintain, within prescribed limits, by bringing into proper or exact position, or by setting the operating characteristics to the specified parameters.

*e. Align.* To adjust specified variable elements of an item to bring about optimum or desired performance.

*f. Calibrate.* To determine and cause corrections to be made or to be adjusted on instruments or test measuring and diagnostic equipments used in precision measurement. Consists of comparisons of two instruments, one of which is a certified standard of known accuracy. to detect and adjust any discrepancy in the accuracy of the instrument being compared.

*g. Install.* The act of emplacing, seating, or fixing into position an item, part, module (component or assembly) in a manner to allow the proper functioning of the equipment or system.

*h. Replace.* The act of substituting a serviceable

like type part, subassembly, or module (component or assembly) for an unserviceable counterpart.

*i. Repair.* The application of maintenance services (inspect, test, service, adjust, align, calibrate, replace) or other maintenance actions (welding, grinding, riveting, straightening, facing, remachining, or resurfacing) to restore serviceability to an item by correcting specific damage, fault, malfunction, or failure in a part, subassembly, module (component or assembly), end item, or system.

*j. Overhaul.* That maintenance effort (service/action) necessary to restore an item to a completely serviceable/operational condition as prescribed by maintenance standards (i.e., DMWR) in appropriate technical publications. Overhaul is normally the highest degree of maintenance performed by the Army. Overhaul does not normally return an item to like new condition.

*k. Rebuild.* Consists of those services/actions necessary for the restoration of unserviceable equipment to a like new condition in accordance with original manufacturing standards. Rebuild is the highest degree of materiel maintenance applied to Army equipment. The rebuild operation includes the act of returning to zero those age measurements (hours, miles, etc.) considered in classifying Army equipments/components.

#### C-3. Column Entries.

*a. Column 1, Group Number.* Column 1 lists group numbers, the purpose of which is to identify components, assemblies, subassemblies, and modules with the next higher assembly.

*b. Column 2, Component/Assembly.* Column 2 contains the noun names of components, assemblies, subassemblies, and modules for which maintenance is authorized.

*c. Column 3, Maintenance Functions.* Column 3 lists the functions to be performed on the item listed in column 2. When items are listed without maintenance functions, it is solely for purpose of having the group numbers in the MAC and RPSTL coincide.

*d. Column 4, Maintenance Category.* Column 4

specifies, by the listing of a “work time” figure in the appropriate subcolumn(s), the lowest level of maintenance authorized to perform the function listed in column 3. This figure represents the active time required to perform that maintenance function at the indicated category of maintenance. If the number or complexity of the tasks within the listed maintenance function vary at different maintenance categories, appropriate “work time” figures will be shown for each category. The number of task-hours specified by the “work time” figure represents the average time required to restore an item (assembly, subassembly, component, module, end item or system) to a serviceable condition under typical field operating conditions. This time includes preparation time, troubleshooting time, and quality assurance/quality control time in addition to the time required to perform the specific tasks identified for the maintenance functions authorized in the maintenance allocation chart. Subcolumns of column 4 areas follows:

- C–Operator/Crew
- O–Organizational
- F–Direct Support
- H–General Support
- D–Depot

*e. Column 5, Tools and Equipment.* Column 5 specifies by code, those common tool sets (not individual tools) and special tools, test, and support equipment required to perform the designated function.

*f. Column 6, Remarks.* Column 6 contains an

alphabetic code which leads to the remark in section IV, Remarks, which is pertinent to the item opposite the particular code.

**C-4. Tool and Test Equipment Requirements (Sect. III).**

*a. Tool or Test Equipment Reference Code.* The numbers in this column coincide with the numbers used in the tools and equipment column of the MAC. The numbers indicate the applicable tool or test equipment for the maintenance functions.

*b. Maintenance Category.* The codes in this column indicate the maintenance category allocated the tool or test equipment.

*c. Nomenclature.* This column lists the noun name and nomenclature of the tools and test equipment required to perform the maintenance functions.

*d. National/NATO Stock Number.* This column lists the National/NATO stock number of the specific tool or test equipment.

*e. Tool Number.* This column lists the manufacturer's part number of the tool followed by the Federal Supply Code for manufacturers (5-digit) in parentheses.

**C-5. Remarks (Sect. IV).**

*a. Reference Code.* This code refers to the appropriate item in section II, column 6.

*b. Remarks.* This column provides the required explanatory information necessary to clarify items appearing in section II.

(Next printed page is C-3)

SECTION II MAINTENANCE ALLOCATION CHART

FOR  
 SHELTER, ELECTRICAL EQUIPMENT S-280C/G and  
 SHELTER, ELECTRICAL EQUIPMENT S-280C/G (with Rivnuts)

(1) GROUP NUMBER	(2) COMPONENT/ASSEMBLY	(3) MAINTENANCE FUNCTION	(4) MAINTENANCE CATEGORY					(5) TOOLS AND EQPT.	(6) REMARKS
			C	O	F	H	D		
00	SHELTER, ELECTRICAL EQUIPMENT S-280C/G	Inspect Service Repair Repair Repair		0.5 0.5 0.5	1.0	2.0		1 1,2 1,2,3 4	A B C D E
01	DOOR ASSEMBLY	Repair Repair			0.5	1.0		1,2 1,2	F
02	SKID ASSEMBLY	Repair				2.0		1,2	
03	LIFTING AND TIE EYE ASSEMBLY	Replace			0.5			1,2	G
04	TOWING EYE	Replace			0.5			1,2	G
05	DOOR BRACE ASSEMBLY	Repair			0.5			1,2,3	
06	PAN ASSEMBLY, RECESSED STEP	Repair			0.5			1,2	H

SECTION III TOOL AND TEST EQUIPMENT REQUIREMENTS  
 FOR  
 SHELTER ELECTRICAL EQUIPMENT AND  
 SHELTER ELECTRICAL EQUIPMENT S-280C/G (WITH RIVNUTS)

TOOL OR TEST EQUIPMENT REF CODE	MAINTENANCE CATEGORY	NOMENCLATURE	NATIONAL/NATO STOCK NUMBER	TOOL NUMBER
1	F, H, D	TOOLS AND MATERIALS LISTED IN TB 43-0123	N/A	
2	F, H	TOOL KIT, AUTOMOTIVE MECHANICS		
3	F, H	TOOL KIT, ELECTRONIC EQUIPMENT SHELTER TK-144/G	5180-00-973-4369	
4	D	DEPOT FACILITIES		

NOTE

THE NATIONAL STOCK NUMBER THAT IS MISSING FROM  
 THIS LIST HAS BEEN REQUESTED AND WILL BE ADDED  
 BY A CHANGE TO THE LIST UPON RECEIPT.

## SECTION IV. REMARKS

REFERENCE CODE	REMARKS
A	SERVICE INCLUDES CHANGING AIR FILTER, LUBRICATE DOOR HINGES, LATCH MECHANISM AND STOP. CLEANING INTERIOR AND EXTERIOR AND TOUCH UP PAINTING.
B	MINOR REPAIR OF SKIN PUNCTURES IN ACCORDANCE WITH THE PROCEDURES OF TB 43-0124. REPLACE SLING ASSEMBLY COMPONENTS.
C	REPAIR SKIN PUNCTURES IN ACCORDANCE WITH THE PROCEDURES OF TB 43-0124. REPLACE PARTS ATTACHED BY THREADED FASTENERS.
D	REPAIR IN ACCORDANCE WITH PROCEDURES IN TB 43-0124. REPAIR INCLUDES REPLACEMENT OF RIVNUTS AND DELAMINATED SKIN REPAIR.
E	REPAIR REQUIRES USE OF DEPOT FIXTURES FOR LIFTING AND TOWING EYE TESTS AND CONSTRUCTION TIGHTNESS TEST.
F	REPLACE RAIN FLOP, RFI AND WEATHER GASKETS, LOUVRE AND RFI HONEYCOMB ASSEMBLIES.
G	REPLACE RING ASSEMBLY.
H	REPLACE STEP.





RECOMMENDED CHANGES TO EQUIPMENT TECHNICAL PUBLICATIONS



THEN... JOT DOWN THE DOPE ABOUT IT ON THIS FORM. CAREFULLY TEAR IT OUT. FOLD IT AND DROP IT IN THE MAIL!

SOMETHING WRONG WITH THIS PUBLICATION?

FROM (PRINT YOUR UNIT'S COMPLETE ADDRESS)  
 Commander  
 Stateside Army Depot  
 ATTN: AMSTA-US  
 Stateside, N.J. 07703

DATE SENT  
 10 July 1975

PUBLICATION NUMBER TM 11-5840-340-20P	PUBLICATION DATE 23 Jan 78	PUBLICATION TITLE Radar Set AN/PRC-76
--	-------------------------------	--

BE EXACT. PIN-POINT WHERE IT IS				IN THIS SPACE TELL WHAT IS WRONG AND WHAT SHOULD BE DONE ABOUT IT:
PAGE NO	PARA-GRAPH	FIGURE NO	TABLE NO	
33				For item 2, change the NSN to read: 5835-00-134-9186. Reason: Accuracy.
44		19		Identify the cover on the junction box (item no. 5). Reason: It is a separate item and is not called out on figure 19.
45				Add the cover of the junction box as an item in the listing for figure 19. Reason: Same as above

S  
A  
M  
P  
L  
E

TEAR ALONG PERFORATED LINE

PRINTED NAME, GRADE OR TITLE AND TELEPHONE NUMBER SSG I. M. DeSpirit of 999-1776	SIGN HERE 
---	---------------



RECOMMENDED CHANGES TO EQUIPMENT TECHNICAL PUBLICATIONS

**SOMETHING WRONG WITH THIS PUBLICATION?**



THEN JOT DOWN THE DOPE ABOUT IT ON THIS FORM. CAREFULLY TEAR IT OUT. FOLD IT AND DROP IT IN THE MAIL.

FROM (PRINT YOUR UNIT'S COMPLETE ADDRESS)

DATE SENT

PUBLICATION NUMBER  
TM 11-5410-213-14P-1

PUBLICATION DATE  
5 Jan 82

PUBLICATION TITLE  
Shelter, Electrical Equipment  
S-280C/G

BE EXACT PIN-POINT WHERE IT IS

PAGE NO	PARA-GRAPH	FIGURE NO	TABLE NO

IN THIS SPACE TELL WHAT IS WRONG AND WHAT SHOULD BE DONE ABOUT IT:

PRINTED NAME GRADE OR TITLE AND TELEPHONE NUMBER

SIGN HERE

TEAR ALONG PERFORATED LINE

FILL IN YOUR  
UNIT'S ADDRESS

FOLD BACK

DEPARTMENT OF THE ARMY

OFFICIAL BUSINESS

Commander  
US Army Communications-  
Electronics Command  
ATTN: DRSEL-ME-MQ  
Fort Monmouth, New Jersey 07703

TEAR ALONG PERFORATED LINE



FILL IN YOUR  
UNIT'S ADDRESS

FOLD BACK

DEPARTMENT OF THE ARMY

OFFICIAL BUSINESS

Commander  
US Army Communications-  
Electronics Command  
ATTN: DRSEL-ME-MQ  
Fort Monmouth, New Jersey 07703

TEAR ALONG PERFORATED LINE

RECOMMENDED CHANGES TO EQUIPMENT TECHNICAL PUBLICATIONS

**SOMETHING WRONG WITH THIS PUBLICATION?**



THEN JOT DOWN THE DOPE ABOUT IT ON THIS FORM. CAREFULLY TEAR IT OUT. FOLD IT AND DROP IT IN THE MAIL.

FROM (PRINT YOUR UNIT'S COMPLETE ADDRESS)

DATE SENT

PUBLICATION NUMBER

TM 11-5410-213-14P-1

PUBLICATION DATE

5 Jan 82

PUBLICATION TITLE

Shelter, Electrical Equipment  
S-280C/G

BE EXACT PIN-POINT WHERE IT IS

PAGE NO	PARA-GRAPH	FIGURE NO	TABLE NO

IN THIS SPACE TELL WHAT IS WRONG AND WHAT SHOULD BE DONE ABOUT IT:

PRINTED NAME GRADE OR TITLE AND TELEPHONE NUMBER

SIGN HERE

TEAR ALONG PERFORATED LINE

FILL IN YOUR  
UNIT'S ADDRESS

FOLD BACK

DEPARTMENT OF THE ARMY

OFFICIAL BUSINESS

Commander  
US Army Communications-  
Electronics Command  
ATTN: DRSEL-ME-MQ  
Fort Monmouth, New Jersey 07703

TEAR ALONG PERFORATED LINE



Order of the Secretary of the Army

Official:

ROBERT M. JOYCE  
*Brigadier General, United States Army*  
*The Adjutant General*

E. C. MEYER  
*General, United States Army*  
*Chief of Staff*

**DISTRIBUTION:**

To be distributed in accordance with Special List.





